



SUNJIN ROCK GRINDER

SUNJIN ROCK GRINDER



Main features

1. Low vibration reduces fatigue.
2. Maximum cutting performance and minimum service thanks to unique transmission technology.
3. Low-maintenance thanks to robust drive shaft and heavy duty sealing system
4. Underwater operation without additional installation unlike hydraulic breaker thanks to gear sealing system.
5. Wear-resistant tungsten carbide tip to withstand extreme stress and impact.
6. High torque hydraulic motor for higher productivity and longer motor lifetime
7. Robust housing design with Hardox wear protection for higher uptime.
8. Lubrication free slide ring seal system.





RGL single head rock grinder

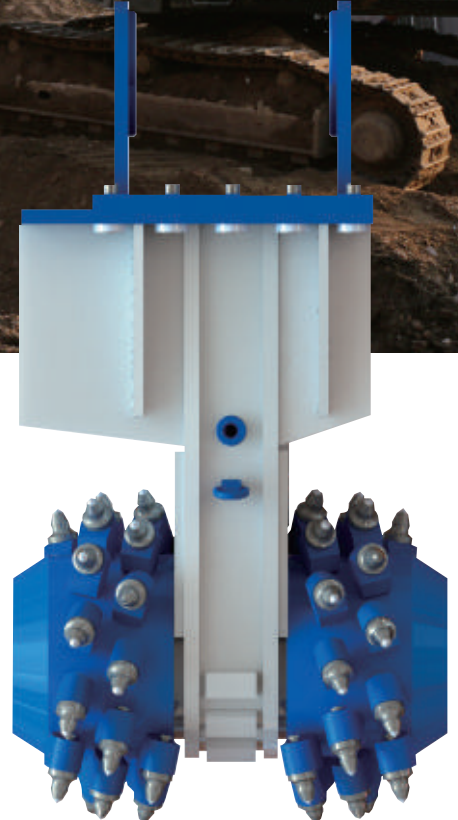

RG twin head rock grinder

Applications for Rock Grinder



Bucket



Rock Grinder



Hydraulic breaker

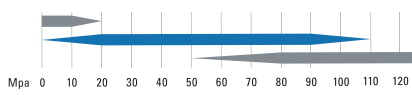

Rock Grinders use robust spur gears driven by high torque motors.

The picks on twin drums will penetrate and remove materials through a combination of crushing and cutting action.

The optimum number of pick and pick arrangement ensure maximum cutting performance, minimum vibration and quiete operation.

FOR TOUGH APPLICATIONS



Applications



1. Trench / Pipeline construction

Rock Grinders produce smooth trench wall with straight parallel sides. Trenches can be excavated accurately to the size required. The grained materials can be re-used as back fill without additional crushing



2. Tunneling

Rock Grinders are commonly used for scaling operation in tunnel construction after drill and blast. Profiling work also Rock Grinder's common work in tunnel construction after blasting, before nstallation of support or after shotcreting.



3. Foundation work

Rock Grinders ensure safe cut under existing services and pipes. Deep excavation for underground construction work, site preparation and leveling work can be successfully done by Rock Grinders,



4. Demolition / Building renovation with low vibration

Rock Grinders are used in urban demolition site where extremely low noise and vibration level are required.

Rock Grinders can be also used for rehabilitation of sensitive concrete structures such as foundations and bridge abutments and for excavation near lock gates.



5. Profiling / Leveling

Rock Grinder can be used to profile embankments



6. Quarrying / Excavating

Rock Grinders are an ideal tool for excavating soil, soft rock, asphalt and concrete. Its combination of cutting force and cutting precision ensure high performance and productivity in those job sites.

Gypsum and limestone mining are most suitable job site for Rock Grinders.

RG TWIN HEAD ROCK GRINDER

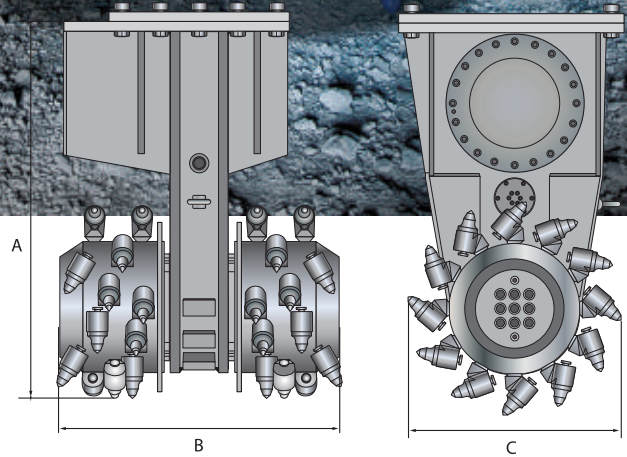
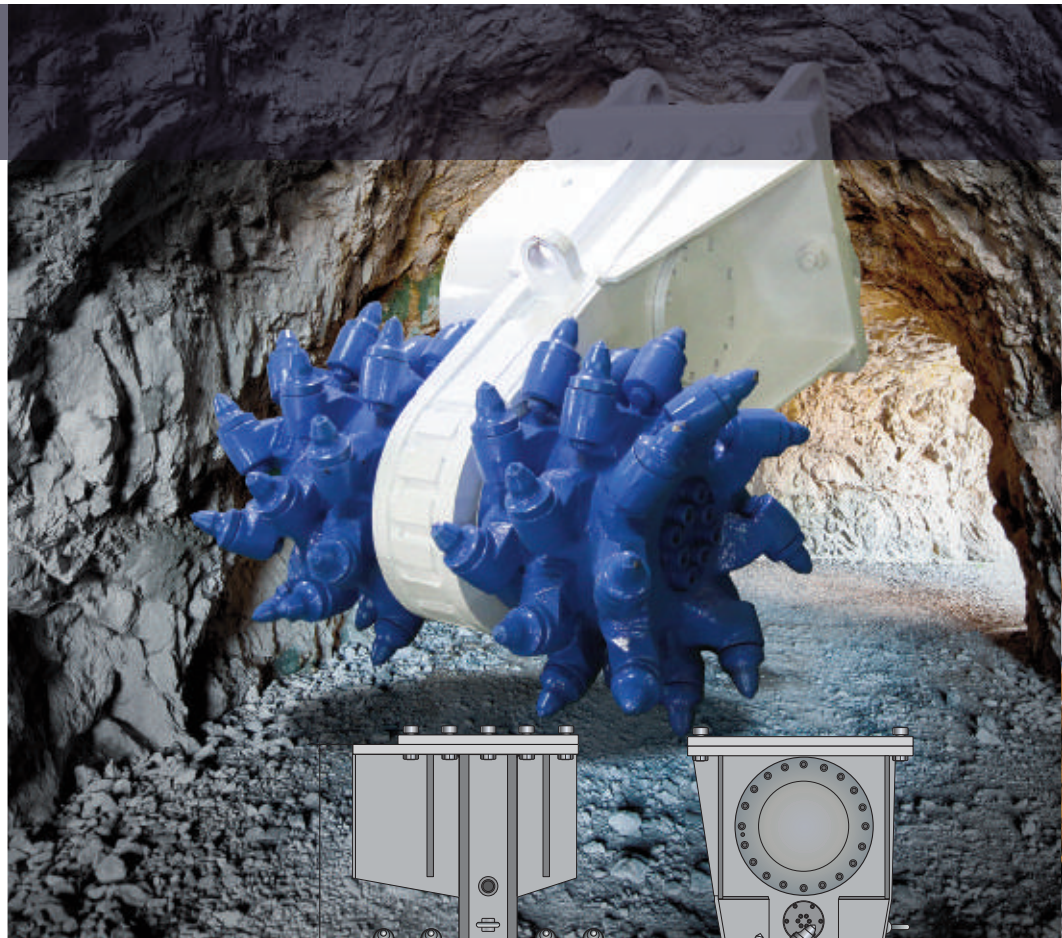

• Standard Specification

Technical Data	UNIT	RG05	RG10	RG15	RG30	RG40	RG50
Carrier weight class	ton	3 - 7	7 - 15	12 - 18	20 - 33	25 - 40	35 - 50
Service weight	kg	390	420	800	1,750	1,850	2,350
Oil flow rate	l/min	49 - 90	75 - 124	109 - 170	190 - 320	190 - 320	275 - 410
Max. operating pressure	bar	350	350	350	350	350	350
Rotational speed	rpm	90 - 160	80 - 135	60 - 110	60 - 90	50 - 90	55 - 85
Max. cutting force@350bar	N	17,800	23,200	36,200	58,200	69,900	81,800
Max.Torque@350bar	Nm	3,150	5,200	10,400	19,500	23,400	27,800
Max. rock hardness	MPa	25	40	50	70	80	100
Length of rock grinder	A	740	740	990	1,200	1,200	1,300
Width of grinder head	B	615	660	730	880	920	950
Diameter of grinder head	C	370	370	560	670	670	710
Number of picks	PC	64	64	48	48	48	56
Pick shank diameter	mm	20	20	25	30	30	30

※ Above specification can be changed without a previous notice for improvement in quality

RGL SINGLE HEAD ROCK GRINDER

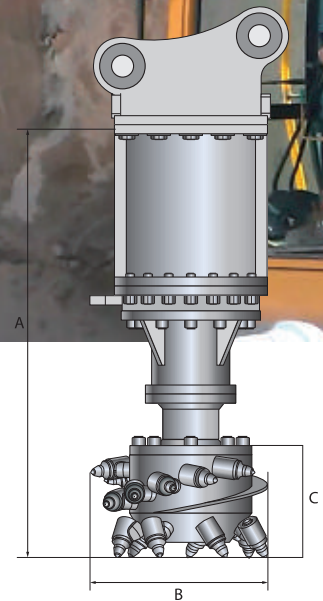

• Standard Specification

Technical Data	UNIT	RG20L	RG30L	RG40L
Carrier weight class	ton	15 - 23	20 - 30	25 - 35
Service weight	kg	820	1,200	1,200
Oil flow rate	l/min	140 - 250	180 - 300	180 - 300
Max. operating pressure	bar	350	350	350
Rotational speed	rpm	60 - 90	60 - 90	50 - 90
Max. cutting force@350bar	N	50,400	58,200	69,900
Max.Torque@350bar	Nm	14,000	19,500	23,400
Max. rock hardness	MPa	60	70	80
Length of Rock Grinder	A	990	1,200	1,200
Width of grinder head	B	750	880	920
Diameter of grinder head	C	560	670	670
Number of picks	PC	30	48	48
Pick shank diameter	mm	25	30	30

※ Above specification can be changed without a previous notice for improvement in quality



CONSTRUCTION EQUIPMENT

#506, IS biztower, 80, Yangpyeong-dong 4-ga,
Yeongdeungpo-gu, Seoul, Korea
Phone : +82-2-2637-0502 Fax : +82-2-2637-0504
E-mail : sales@sunjince.com
www.sunjince.com

Contact